

TERMS AND CONDITIONS OF TENDERING (FOR QUOTATION WORKS)

1. Before tendering, the tenderer shall visit the site where the Works are to be carried out and shall also carefully examine the relevant Terms and Conditions of Contract, Drawings, Specification and all other accompanying schedules, etc.

If there is any ambiguity in or discrepancy between any of the documents, he / she should refer the matter to **MOHD. YUSSOF BIN HAJI ABDULLAH (8858656)**, **Estet Maintenance Hospital PIHM, Ministry of Health [Tel: 5221526/27 ext. 219/135]**.

On tendering, the tenderer shall be deemed to have examined the documents referred to above and shall be bound by the terms and conditions therein.

2. Every tenderer must submit together all documents listed below and this requirement shall be strictly adhered to prior to any consideration: -

- (a) Valid Tenderer's Registration Certificate from the Ministry of Development / Ministry of Health.
- (b) Business Enactment Act Section 16 & 17.
- (c) The Tender Form **MUST** be signed by the Owner, or the Director of Shareholder(s) of the Company stating their post and stamped with the Company's Official seal as detailed in the Business Enactment Act Section 16 & 17 / or the tenderer's Registration Certificate from the Ministry of Development.
- (d) The address indicated must be detailed as in the Business Enactment Act Section 16 & 17 / and/or Tenderer's Registration Certificate from the Ministry of Development. Any changes to the above must be officially referred to the Registrar of Companies and Business Names and a copy must be submitted to this department.

Tender documents must be duly completed, signed and dated. Any tender which is incomplete or unsigned will render the tender to be rejected.

3. (a) Tenders and documents in connection therewith as specified above, must be delivered to the place at or before the time specified.
(b) In the case of the tender not being delivered by hand, the tenderer must arrange for his / her tender and other documents to be posted in time to reach the stipulated place by not later than the time stated.
(c) In no case will the Government be responsible for any expense or loss incurred by a tenderer in the preparation of this tender.

Tenders shall remain valid for **3 MONTHS** from the final date for submission of the tenders and no tenderer may withdraw his/her tender within that period. The Government reserves the right to extend this period if deemed necessary provided that such extension of the tender validity period shall have the written consent of the tenderers.

4. The Government does not bind itself to accept the lowest and/or any tender and no reason will be given for rejecting any tender thereof.
5. Every correspondence to be given to a tenderer may be posted to the tenderer's address in the tender and such posting shall be deemed good and legally binding in service of such correspondence.
6. The tender shall be made on the basis of the rates in the tender documents being firm and not subject to any adjustment with variations in quantities.
7. The tender fee shall be **BS5.00 [Five Dollar Only]**
8. No unauthorised alteration or use of 'blanco' in the tender documents is allowed, or the tender may be rejected. Any errors are to be struck off and initialed.
9. Non-compliance with the above terms and conditions in any respect may render the tender liable to be rejected.
10. The tender must be done in the official printed tender forms which is available from the **PURCHASING AND PROCUREMENT SECTION, MINISTRY OF HEALTH.**

The completed tender documents are to be lodged on or before 2:00 PM on WEDNESDAY in a sealed enveloped addressed to :-

TENDER / QUOTATION (QTN) BOX

PENGERUSI SEBUTHARGA
HOSPITAL PIHM, TEMBURONG
KEMENTERIAN KESIHATAN
NEGARA BRUNEI DARUSSALAM

The top part of the sealed envelope must be written stating the following :-

Quotation No. : _____ Quotation Closing Date : _____
Title : TO SUPPLY AND INSTALLATION MEDICAL VACUUM PUMP WITH ALL ACCESSORIES NECESSARY
REQUIREMENT FOR MALE WARD, FEMALE WARD AND PEADIATRIC/ISOLATION WARD HOSPITAL
PENGIRAN ISTERI HAJJAH MARIAM (PIHM) TEMBURONG.

RINGKASAN TAWARAN
SUMMARY OF QUOTATION

Tajuk / Title : TO SUPPLY AND INSTALLATION MEDICAL VACUUM PUMP WITH ALL ACCESSORIES NECESSARY
REQUIREMENT FOR MALE WARD, FEMALE WARD AND PEADIATRIC/ISOLATION WARD HOSPITAL
PENGIRAN ISTERI HAJJAH MARIAM (PIHM), TEMBURONG

Bil. Sebutarga : Ruj. Permohonan : No. MOH :
Quotation No. : Request Ref. : MOH No. :

Muka Page 1 Dari Of 2

Bil. No.	Keterangan / Description	Unit Unit	Kuantiti Quantity	Jumlah Amount		
				Kadar Rate	\$	¢
	<p>Note: The contractor shall carry out 'site visit' inspection and take into account all aspects and conditions of site before submitting his quotation. The contractor must fill this schedule at the time of tendering. Supply all materials, labour, tools and everything else deemed necessary to carry out work as specified to the following. Contractor having submitted their prices are considered as having visited the site. No claims for additional payment will be entertained on the ground of misunderstanding or misinterpretation of the conditions, measurement etc.</p>					
1	<u>MEDICAL VACUUM PUMP PACKAGE PLANT</u>					
1.1	Consisting of following equipment and assembly parts Oil-less dry vacuum pump set 2.4 kw Max Vacuum: -99 kPa Flow Rate: 1,120 l/min (at-80kPa) Tank capacity: 500 litre Brand: Becker or equivalent Made: Germany or Europe, Asia	sets	2			
1.2	Vacuum receiver tank 500 litre with vacuum gauge and switch	set	1			
1.3	Vacuum filter assembly	sets	2			
1.4	Automatic/Alternate/Parallel operation control cabinet	set	1			
JUMLAH DIBAWA KE DEPAN AMOUNT CARRIED FORWARD						

Bil. No.	Keterangan / Description	Unit Unit	Kuantiti Quantity	Jumlah Amount		
				Kadar Rate	\$	₹
1.5	Steel base for two vacuum pumps	set	1			
1.6	Piping accessories and materials for package unit and electrical works	set	1			
<p>Tempoh Penyiapan / Penghantaran: 3 BULAN</p> <p>Tempoh warranty: 12 BULAN</p> <p>List of warranty item: _____</p> <p>*Please fill the list warranty item.</p>						
<p>JUMLAH KESELURUHAN BAGI RINGKASAN TAWARAN INI PART A-ITEM 1.0</p> <p>TOTAL AMOUNT FOR THIS SUMMARY OF TENDER CARRIED TO PART A – AGREEMENT ITEM 1.0</p>						

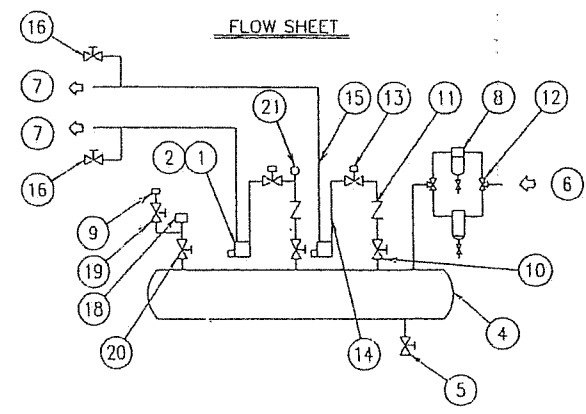
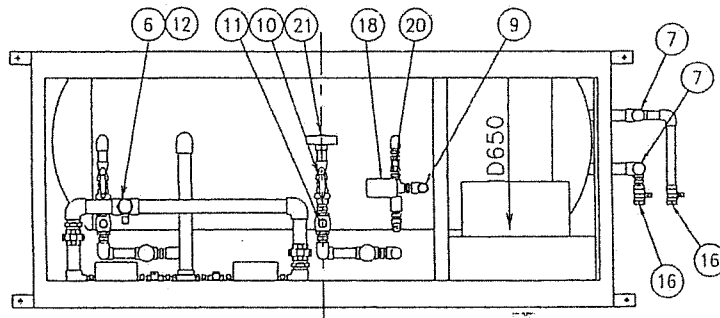

SPECIFICATIONS

PUMP	
MAX. VACUUM	-99 kPa
FLOW RATE	1.20 9.7 l/min (at -80kPa)
MOTOR	
POWER	2.0 2.4 kW
POLE	4 P
VOLTAGE	3φ 220V 60Hz
TANK CAPACITY	500 500 l
MASS	560 kg

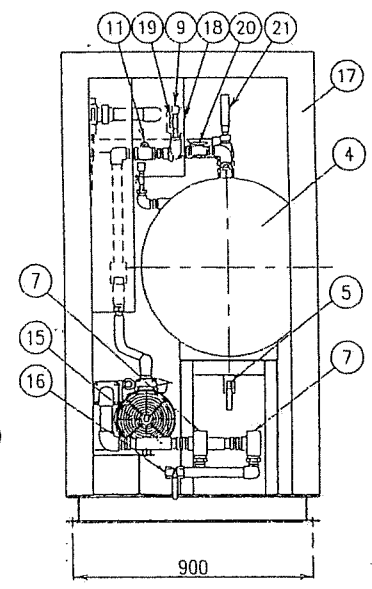
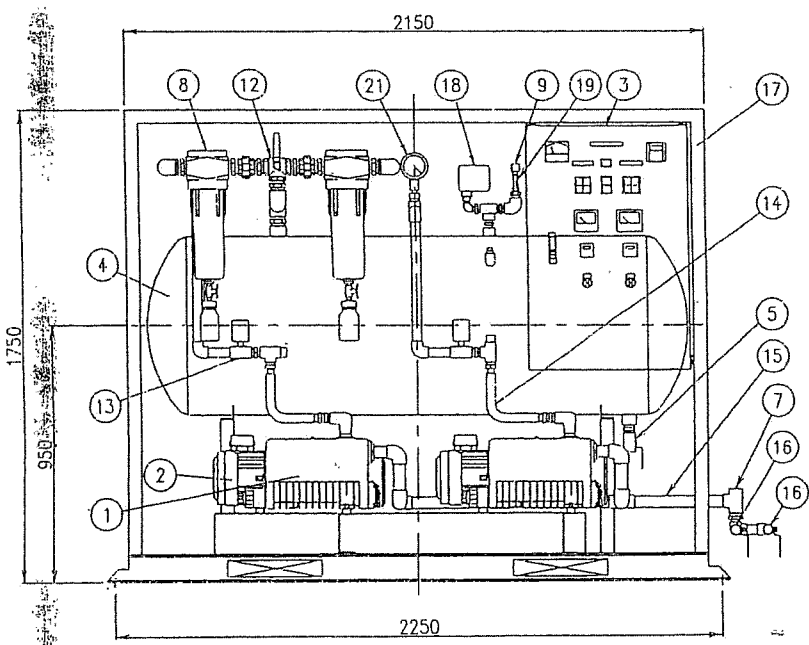

No	N A M E	Q.ty	MATERIAL	JIS	R E M A R K S
21	VACUUM GAUGE	1			AT 1/4x100x-100kPa
20	STOP VALVE FOR VACUUM SWITCH	1	C 3771BE	H 3250	Rc 1/4
19	STOP VALVE FOR SENSOR	1	C 3771BE	H 3250	Rc 3/8
18	VACUUM SWITCH	1			VL-500-3T(FOR BACKUP)
17	FRAME	1	SS400	G 3101	COLOR 10B3.5/1 10PBS/10
16	OUTLET DRAIN VALVE	1	C 3771BE	H3250	Rc 1
15	EXHAUST PIPE	2	SGP		1 1/4 B
14	INTAKE HOSE	2	PVC		1 B
13	ELECTRIC CONTROLLED BALL VALVE	2	BC6	H 5111	Rc 1
12	3-WAY VALVE	2	C 3771BE	H 3250	Rc 1 1/2
11	CHECK VALVE	2	BC	H 5111	Rc 1
10	BALL VALVE	2	C 3771BE	H 3250	Rc 1
9	PRESSURE SENSOR	1			PA500-102V
8	VACUUM FILTER	2			0.01 μm Rc 1 1/2
7	AIR OUTLET	2			Rc 1 1/4
6	AIR INLET	1			Rc 1 1/2
5	DRAIN VALVE	1	C 3771BE	H 3250	1/2B BV
4	VACUUM TANK	1	SS400	G 3101	500 l
3	CONTROL PANEL	1			AUTOMATIC ALTERNATE & PARALLEL RUN
2	MOTOR	2			2.4kW-E
1	VACUUM PUMP BODY	2			

* CONTROL PANEL SHALL NOT BE MOUNTED ON THE STATION
BUT ON THE WALL OF THE MACHINE ROOM

TITLE	VACUUM STATION 2.0 2.4 KW	PRODUCT No.	SCALE
MODEL	PACKAGED TYPE	APPROVED BY H.Komatsu	DATE 2006.08
		DESIGNED BY	DWG.No.

**ESTATE MANAGEMENT
MINISTRY OF HEALTH**

<input type="checkbox"/>	1. _____
	2. _____
	3. _____
FOR OFFICIAL USE ONLY.	

Quotation For : **TO SUPPLY AND INSTALLATION MEDICAL VACUUM PUMP WITH ALL ACCESSORIES NECESSARY REQUIREMENT FOR MALE WARD, FEMALE WARD AND PEADIATRIC /ISOLATION WARD HOSPITAL PENGIRAN ISTERI HAJJAH MARIAM (PIHM) TEMBURONG**

Quotation No : _____ Closed On : _____ Receipt No. : _____

PART A - AGREEMENT

1.0 On behalf of
I, the undersigned, agree to carry out the above Works/Service/Supply* for a sum of B\$ _____
(Brunei Dollars _____)
within a period of **3** Days /Weeks/ Months* in accordance with the terms and conditions below.

2.0 Name & Signature : _____
As Owner /Director* (_____)

2.1 IC No. : _____

2.2 Name & Signature : _____
of Witness (_____)

2.3 IC No. : _____

2.4 Address : _____

2.5 Telephone No. : _____ Fax No. : _____ E-mail : _____

2.6 Date : _____

Company Stamp

FOR OFFICIAL USE ONLY.

3.0 On behalf of the Brunei Government, I accept your offer to carry out all/ items* _____
of the above for a sum of B\$ _____ (Brunei Dollars _____)
within a period of **3** Days / Weeks / Months* in accordance with the terms and conditions below.

4.0 _____
(_____)

4.1 _____
For Senior Special Duties Officer

4.2 Name & Signature : _____
of Witness (_____)

4.3 Address : _____

4.4 Telephone No. : _____ Fax No. : _____ E-mail : _____

4.5 Date of Contract : _____

5.0 The Contract Administrator is : _____

6.0 The Starting Date is on : _____

* Delete as necessary

Department Stamp

PART B - TERMS OF QUOTATION

1.0 BASIS OF QUOTATION, OVERALL OBLIGATIONS AND ADMINISTRATION

1.1 Overall Obligations of the Government:

- 1.1.1 To provide access at proper times for the Contractor to do his work.
- 1.1.2 To provide all information and facilities stated in this contract to enable the Contractor to do his work.
- 1.1.3 To pay the Contractor as provided in this Contract.
- 1.1.4 To assign a Contract Administrator to administer this Contract.
- 1.1.5 May take out or renew insurances referred to in Clause 1.2.4 below if the Contractor fails to do so.

1.2 Overall Obligations of the Contractor:

- 1.2.1 To finish the Works to the quality standards provided in this Contract within the timeframes and completion period provided in this Contract.
- 1.2.2 To cooperate with all other Contractors working on the project and not to disrupt them or cause damage to them.
- 1.2.3 To provide a collateral warranty containing a similar obligation as under this Contract directly to a third party if requested by the Contract Administrator.
- 1.2.4 To provide and maintain valid Contractor's all risks insurance policy at all times.

1.3 Instructions & Certifications

- 1.3.1 The Contract Administrator can issue instructions and certifications including job orders to the Contractor on anything relating to the Works.
- 1.3.2 All instructions, certifications and job orders must be in writing, dated and clearly identified as Contract Administrator's instructions, certifications or job orders.
- 1.3.3 The Contractor must comply with all instructions, certifications and job orders issued by the Contract Administrator.
- 1.3.4 The Contract Administrator may arrange others to complete the Works if the Contractor fails to comply with Clause 1.3.3, and the Contractor shall pay for all extra costs incurred.

2.0 QUALITY, HEALTH AND SAFETY AND ENVIRONMENT

2.1 Quality

- 2.1.1 The Contractor must do his work based on the documents referred to in this Contract and other instructions and information given to him by the Contract Administrator.
- 2.1.2 If any of the Works is not done according to this Contract or if there is any other breach of this Contract by the Contractor, the Contract Administrator must inform the Contractor of the shortfall(s). The Contractor must rectify the shortfall(s).
- 2.1.3 If the Contractor does not rectify the shortfall(s), The Contract Administrator may arrange others to rectify the shortfall(s). The Contract Administrator can also certify either:
 - (a) The cost of rectifying such shortfall(s); or
 - (b) The reduced value of the completed Works due to such shortfall(s)as provided in the payment certification clause.
- 2.1.4 The Contract Administrator can continue to do this throughout the project and during the Defects Liability Period (as stated in the Appendix) after the Contract Administrator confirms the Works is complete as provided in the completion clause.

2.2 Health, Safety and Environment

- 2.2.1 The Contractor must keep the site clean and safe at all times.
- 2.2.2 The Contractor must comply with all laws and regulations relating to Health, Safety and Environment Act, if any.

3.0 TIME OBLIGATIONS

3.1 Starting, Progress and Finishing

- 3.1.1 If not stated in this Contract, the Contract Administrator will inform the Contractor when to start work in writing.
- 3.1.2 The Contractor must progress with the Works in a regular and diligent manner.
- 3.1.3 The Contract Administrator can instruct the Contractor to stop and restart at any time.
- 3.1.4 The Contractor must finish all the Works within the deadlines stated in this Contract or as instructed by the Contract Administrator.

3.2 Adjusting Time for Completion

- 3.2.1 If the Government or Contract Administrator or anyone within either of their responsibility or control (which includes other contractors on site), or anything beyond the Contractor's control, disrupts the Contractor from finishing within the completion period, the Contract Administrator must assess the impact of this disruption on the Contractor's work to be done.
- 3.2.2 If any Completion Date is affected the Contract Administrator must adjust the Completion Date.
- 3.2.3 This must be done in a written certificate clearly identified as Extension of Time Certificate.

3.3 Completion

- 3.3.1 When the Contractor practically completes all the Works, he may inform the Contract Administrator stating he has completed.
- 3.3.2 The Contract Administrator must decide when the Works was actually practically completed by the Contractor.
- 3.3.3 This decision must be in a written certificate clearly identified as Certificate of Practical Completion.
- 3.3.4 The Contract Administrator must decide when all obligations of the Contractor are fully discharged.
- 3.3.5 This decision must be in a written certificate clearly identified as a final completion certificate.
- 3.3.6 This must be done after the end of Defects Liability Period (as stated in the Appendix) or when the Contractor has rectified all the shortfall(s) including Works that is not according to this Contract and any other breach of Contract by the Contractor identified by the Contract Administrator, whichever is later.

3.4 Delayed Completion

- 3.4.1 If the Contractor does not finish within any deadline he shall pay Liquidated and Ascertained Damages due to the delay to the Government as provided in the payment certification clause.
- 3.4.2 Liquidated and Ascertained Damages is calculated for delay between when the Contractor should have completed the Works and when he actually completes the Works.

4.0 Variations to Work

- 4.1 The Superintending Officer can issue instructions to vary the Works to be done.
- 4.2 If the Superintending Officer instructs the Contractor to vary any of the Works and there is a financial impact, the Superintending Officer must certify the value of the variation work as provided in the payment certificate clause.
- 4.3.3 The Superintending Officer must value the variation work using the Summary of Works rates. If there are no Summary of Works rates then using schedule of rates or if neither are available using fair market rates.
- 4.3.4 This shall be done in a written certificate clearly identified as Variation Order Certificate.

5.0 PAYMENT CERTIFICATION

5.1 Claims and Payment Certificate

- 5.1.1 The Contractor must submit a claim for the Works done before payment certificate can be issued.

5.2 Contents of Payment Certificate:

- 5.2.1 The payment certificate must include the following:
- 5.2.2 Add the following:
 - (a) Cumulative value of the Works done. This is valued based on Summary of Works rates or schedule of rates, if any. If none, then valued based on fair market rates.
 - (b) Value of variation work properly instructed by the Contract Administrator and properly done by the Contractor.
- 5.2.3 Deduct the following:
 - (a) Liquidated and Ascertained Damages for delayed completion. Liquidated and Ascertained Damages is calculated for delay between when the Contractor should have completed the Works and when he actually practically completes the Works.
 - (b) The value of any shortfall(s) due to work done according to this Contract or due to any other breach of this Contract by the Contractor which the Contract Administrator has informed the Contractor. If the Contractor does not rectify the shortfall(s) the Superintending Officer can certify either:
 - (i) The cost of rectifying such shortfall(s) by others; or
 - (ii) The reduced value of the completed Works due to such shortfall(s) as stated in the Appendix.
 - (c) A percentage of the sum of total additions above will be retained (as the Retention Sum) and released after the end of Defects Liability Period or when the Contractor rectified all the shortfall(s) including work that is not done according to this contract and any other breach of contract by the Contractor identified by the Superintending Officer.
 - (d) The Net Amount Payable is the amount the Government must pay to the Contractor. This is calculated by:

- (i) Adding the total under additions above;
- (ii) Deducting the total of all deductions above; and
- (iii) Deducting the cumulative amount certified previously.

(e) The Contract Administrator may deduct any monies owed by the Contractor to the Government under this or any contract from the Contractor's payments.

6.0 TERMINATION OF CONTRACT

6.1 If the Contractor:

- (a) Suspends the Works before completion without any reasonable cause;
- (b) Fails to proceed with the Works within the time stated in the Superintending Officer instructions;
- (c) Fails to comply with the Superintending Officer's instructions;

for fourteen (14) days after a notice sent to the Contractor, the Superintending Officer can determine this contract by a written notice.

6.2 If the Contractor:

- (d) Becomes bankrupt; or
- (e) Goes into liquidation; or
- (f) Is guilty of any offence under the Prevention of Corruption Act (Chapter 131) or an offence under sections 161 to 165 or 213 to 215 of the Penal Code (Chapter 22).

this Contract is terminated by a written notice.

6.3 In either (6.1) or (6.2) above, the Superintending Officer may complete the Works by other ways and the Contractor shall pay for all extra costs incurred.

6.4 Termination for Convenience:

- (a) The Government may at any time, give the contractor a written notice to terminate the employment of the Contractor under the Contract and the Contractor shall immediately or upon such other date as specified in the written notice;
 - (i) Cease all works under the Contractor, which shall include, but be not limited to such work for the purpose of protecting, making safe or tidying up such part of the works as may already have been executed, or may be in the course of execution.
 - (ii) Vacate the site, remove all his plant, tools, equipment, goods and unfixed materials which have been paid by the government and hand back possession of the site to the Government.

(b) In the event of termination under this Clause, Superintending Officer shall certify the amount payable to the Contractor and the Contractor shall provide all reasonable assistance to the Superintending Officer. In the event that the Contractor does not submit the necessary information required, the Superintending Officer shall make his certification on the information available. The amount certified shall be paid by the Government less any sums previously paid or due to or recoverable by the Government from the Contractor.

PART C - APPENDIX

1.0	Completion Date: (If not stated, to be instructed by the Contract Administrator. If more than one completion period, identify the scope of Works for each completion period) For Term Contract, the Contract shall be ends when the following conditions are met: (a) The actual expiration of the Contract Period; or (b) The limit of the Approximate Maximum Total Value of All Job Orders have been reached: Whichever of the above comes first but subject to Clause 3.2 and Clause 4.0.	3 MONTHS
2.0	Liquidated and Ascertained Damages (LAD): (If none stated, then the Contract Administrator may certify a reasonable sum as compensation for delay)	15% of contract sum No. Of days
3.0	Shortfalls / Defects Liability Period: (If none stated, Six (6) MONTHS from the date of completion)	12 Months
4.0	Retention Sum (If none stated, FIVE (5%) PERCENT of the Contract Sum)	10 % of the Contract Sum
5.0	Minimum and Maximum Values of Job Orders: Minimum value of any one Job Order to be issued Maximum value of any one Job Order to be issued (If none stated, the maximum value to be issued must be capable of being carried out and completed within the Contract Period)	< B\$ > B\$
6.0	Approximate Maximum Total Value of All Job Orders for the Contract Period: (If not stated, NOT MORE THAN \$2,000.00 - BRUNEI DOLLARS TWO THOUSAND) The Superintending Officer gives no warranty or undertaking as to the actual amount of Works that will be issued through Job Orders and no variance in the actual value of Works ordered shall give rise to change in any rate, price or percentage adjustment.	< B\$

SCOPE OF WORKS AND PARTICULAR SPECIFICATIONS (ELECTRICAL)

1. The contractor shall include relocation or removing of any objects properly obstructing the project area to another area as per instructed by the supervising officer incharge without any additional charges to the government and without any delay to the project. I.e. government equipments, boxes, tables, chairs and etc.
2. Any kind / types of defects during installation, relocation, of any government property by the contractor must be replace with new one match existing at the nearest time possible without any extra charges or delay to the government.
3. The successful contractor shall ensure all the materials are genuine and high quality.
4. The contractors must provide 1 (ONE) person on-site supervisor / foreman. And these on-site supervisor / foreman must be on-site all the time during the works in progress.

5. DEFECT

Where items of equipment forming parts of major components have failed during Warranty period and have already the Government of the benefits of the contractor works. The S.O may at his discretion retain for a period of the payment of the full value of the final certificate and retention sum. The period of retention sum may be extended for an equal period during which failure occurs.

Where manufacturers are nominated in this specification or in the following schedule they are intended to define acceptable standards of equipment. Tenderer may submit alternative equipment which shall be at least equal in every respect to the nominated items :

6. WARRANTY

All / every works and new items installed will be under warranty for **TWELVE (12) months**. All defects items during the warranty period need to be replace immediately by new one match existing items or equivalent as approved by the supervising in-charge without any additional charges to the government. All the warranty plates must be properly engraved and installed at the proper places each of the works as approved by the supervising officer in-charge, which every plate must be mention the warranty expired with contractors company names

on it. The size for the aluminium plates warranty shall be 6cm x 4cm. The aluminium plates warranty price should be already include in the summary of tender.

All / every warranty will be commence after the whole project have been completed. For more detail the contractor may contact the contact person or supervising officer incharge.

Government shall not be responsible to any wrong supply of materials and parts or accessories, supervising officer incharge have the right to instruct the contractor to supply the correct materials and parts or accessories without any extra charges and delay to the government.

The contractor must not leave any of their tools, materials, equipments or belongings onsite after office hours and Brunei Government will not take any responsibility for any lost during or after the progress.

SITE VISIT FORM TENDERER

REFERENCE NO.: _____

PROJECT TITLE: _____

This is to confirm and verify that the company stated below has visited and understood the specifications stated in the tender above.

This site visit is a **Mandatory** for Every Tenderer to participate a tender. Without this site visit with our representative from Estate Maintenance Section MOH, and client, the tender shall be considered **NON-COMPLY**.

Name of Company	
Company Stamp	
Name of the Staff	
Position	
Date of Visit	
Verified by Representative from End User, Department:	
Name	
Signature	
Date	
Verified by Representative from Estate PIHM Hospital:	
Name	
Signature	
Date	