

TENDER REFERENCE NO.: KK/50/2026/ESTETMOH

**MINISTRY OF HEALTH
NEGARA BRUNEI DARUSSALAM**

**UPGRADING WORKS FOR PUBLIC TOILET AT GROUND
FLOOR, SURI SERI BEGAWAN HOSPITAL KUALA BELAIT,
KEMENTERIAN KESIHATAN**

TENDER FEES : \$10.00

RECEIPT NO. :

CLOSING DATE : 28th April 2026

TIME : 2.00 PM

FOA :

**THE CHAIRMAN
MINI TENDER BOARD, TENDER BOX
GROUND FLOOR, MINISTRY OF HEALTH
COMMONWEALTH DRIVE
BANDAR SERI BEGAWAN BB3910
NEGARA BRUNEI DARUSSALAM**

(CLUSTERING)

TABLES OF CONTENTS

<u>SECTION</u>	<u>DESCRIPTION</u>	<u>PAGES</u>
SEC A	GENERAL CONDITIONS	2 - 3
SEC B	SPECIFICATIONS	4 - 7

SECTION A

GENERAL CONDITIONS

A.1 **CONTRACT DOCUMENTS**

This particular specification is supplementary to the Public Works Department, General Specification for Building and Construction Works (Revised 1988) and its revision are as follows :-

- a). Reference to the following British Standards (B.S) shall be amended to Piawai Brunei Darussalam (PDB) as follows:

BS 4483 is amended to PBD:2:1992

1. BS 4449 is amended to PBD:3:1992
2. BS 4466 is amended to PBD:4:1992
3. BS 4482 is amended to PBD:5:1992
4. BS 3184 is amended to PBD:13:1994
5. BS 12 is amended to PBD:14:1994
6. BS 449 part 1 is amended to PBD:15 Part 1:1994
7. BS 449 part 2 is amended to PBD:15 Part 2:1994
8. BS 4 part 1 is amended to PBD:17 Part 1:1995
9. BS 3921 is amended to PBD :20:1997

- b). Section 9 of the General Specification for Building and Construction Works (revised 1899) is to be replaced by GS 3: 1998 General Specification for Carpentry and Joinery Produced by the Ministry of Development, Negara Brunei Darussalam.

- c). All Specifications for treated timber shall comply with the Piawai Brunei Darussalam as follow:

1. PBD 8: 1993 – Specification for treated timber products.
2. PBD 16: 1994 – Determination of moisture content of timber.

The Specification, Form Tender and Letter of Acceptance together with the Documents referred therein, Drawings and Standard P.W.D. Schedules of rates for building and Construction Works for variation on contract (current at the time of Tender) General Specification for building and construction works (Revised 1988), the Conditions of contract and other relevant forms shall be deemed to form one Contract and shall be complementary to one another.

A.2 **SCOPE OF WORK**

This contract is for the supply and to provide all necessary labour, materials, supervision, packing, cartage, risks, moving, hoisting, fixing in the required position, plants, tools, implements, scaffolding, screens. Footways, boarding, temporary enclosures, provision of mobile cranes, etc, established charges, profit and every other thing required and the carrying out of all the Conditions of Contract and for the timely and satisfactory completion of the entire works contained in this contract. The contractor shall be deemed to have allowed for all costs or expenses in respects of the above in his Tender Price.

The Contractor shall pay custom duties and any other taxes which may be payable on all materials for use in this contract.

UPGRADING WORKS FOR PUBLIC TOILET AT GROUND FLOOR, SURI SERI BEGAWAN HOSPITAL KUALA BELAIT, KEMENTERIAN KESIHATAN

Allow for all costs or expenses in respect of the above in the tender price.

A.3 **LOCATION OF SITE**

The site is situated at “SURI SERI BEGAWAN HOSPITAL KUALA BELAIT, KA 1131, BELAIT DISTRICT“

A.4 **SITE RESTRICTION**

The contractor shall take all adequate precautions to prevent from damaging any existing works and services. The Contractor shall comply with all regulations that might be imposed by the authorities concerned with regards to the movements of his workmen and materials strictly within the site without causing any overdue damage or disturbance to the private property in vicinity to the site. Any damages unless made good by the Contractor will be recovered from any money become due to the Contractor at the discretion of the Superintending Officer within the site.

The Contractor shall not be permitted to construct any temporary buildings on the site except storage space for materials, etc. as directed and approved by the Superintending Officer.

The Contractor will not be eligible for loss and expenses due to the above site restrictions.

A.5 **SAFETY, HEALTH AND WELFARE OF PEOPLE**
(PWD Circular No. : 25/1989

The Contractor is responsible for the support services in areas of SAFETY, fire protection and prevention, industrial hygiene and is obliged to comply by virtue of statutory requirements as well as being part of the contractual requirements. It is the responsibility of the Contractor that they, their employees and their subcontractor are aware of and familiar with the safety rules and practices as authorized by the S.O.

All reported unsafe practice or unsafe working conditions shall be investigated by the S.O. or his designate.

The Contractor is also responsible for performing work under the contract in a health and safe manner including protecting the safety and welfare of other subcontractors.

(a) **First Aid Box or First Aid Room.**

The Contractor shall provide a suitable first aid box room on site. The Contractor shall provide fire extinguisher on site as instructed by the S.O. The type and quality of the equipment shall be appropriate to the circumstances of the work and to the satisfaction of the S.O.

(b) **Personal Protective Equipment.**

The Contractor shall provide personal protective such as safety helmets, safety goggles and any other safety gears whatsoever necessary to the nature of the works, to all workers and ensure that these safety gears be utilized by his employees.

(c) **Warning Sign**

Warning sign must be provided and maintained at worksites as instructed by the S.O.

(d) **General safety Precautions**

Suitable overhead protection (in the form of safety nets, catch platforms and hoarding, etc.) are to be provided where persons are required to work or pass by places that are normally exposed to falling materials or objects.

(e) **Health and Welfare**

Pay all costs and charges incurred by and comply with all health and welfare regulations pertaining to all persons employed on site.

SECTION B

SPECIFICATIONS FOR MATERIALS AND WORKMANSHIP

B.1 GENERAL

Materials to be used shall be of the best quality approved by the S.O. Workmanship shall be equal to the best in prevailing trade practices. The Contractor shall ensure that all materials are stored properly to prevent deterioration and any handling of the materials shall be done with care to prevent damage.

Materials which fail to comply with the requirements of the specification will be rejected and shall be removed from site forthwith. No claim will be entertained if there is any delay arising therefrom.

B.2 SAMPLES

Samples of materials and fittings shall be submitted for approval as and when directed prior to any order by the Contractor. All samples which are approved shall indicate the standard to be maintained in the execution of the works.

The Contractor shall note that works carried out without submitting samples for prior approval shall, in the event of unsuitability, unacceptability be rejected forthwith without benefit of compensation in either money or time and the Contractor shall be required to replace such works immediately in accordance with the requirement of the S.O.

B.3 ORDERING AND DELIVERY OF MATERIALS

The Contractor shall obtain his materials from approved manufacturers only. The Contractor is to place orders for materials as early as possible after the award of the contract and he shall be responsible for any delay due to the failure to comply with this requirement.

The Contractor must ensure that the quantities of materials ordered and the dates of delivery to the site are such as to enable the works to be satisfactorily completed within the contract period.

The Contractor is not to order any materials from any quantities or size provided in the Summary of Tender but must take all quantities and sizes from the dimensions of the building themselves.

All materials obtained from approved manufacturers shall where applicable be accompanied with test certificate. The S.O. reserves the right to carry out further tests on the materials and to reject any materials that fail to meet the specified requirements. The costs for such tests on these rejected materials shall be borne by the Contractor.

B.4 SCREED

Cement and sand screeds are to be laid as required for floor or wall tiles, finished even and true to the exact line, level or falls required.

B.5 PAINTING WORKS

All plastered surfaces to be painted thoroughly clean and brushed down to remove surplus mortar, all dust, chip off organic/inorganic substances and loose materials.

All exterior paint to be used shall be "Weather Shield" manufactured by ICI or other equal and approved paint with a written guarantee not less than 5 years in accordance with manufacturer's instruction.

Interior paint to be used shall be Pentalite Emulsion manufactured by "ICI" or other equal and approved paint in accordance with manufacturer's instruction.

Contractors shall submit a sample and obtain the approval of the Supervising Officer.

The Contractor should floor-mounted label stating "**WORK IN PROGRESS**" and "**WET PAINT**" at the work site. During the paint works the contractor needs to make sure the entire floor properly fully covered with suitable materials i.e. canvas. Any dirt or defects to the carpet due to the painting work or due to any contractor's works, the contractor must replace with new carpets match existing quantity and design complete with all new underlay and all necessary works needed.

B.6 IRONMONGERIES

All ironmongeries shall comply with requirements of BS 5872. The approved brand shall be of equal and approved quality to "**AllgoodModric**", "**union**", "**Format**", "**Schlage**", "**Kaba**", "**AssaAbloy**", "**QPS**", "**Forte**", "**Hyundae**", "**Lockwood**", "**Chubb**", "**Stremler**", "**Mab**", "**Casma**" and to be in silver anodized aluminium unless as approved by the supervising officer incharge.

B.7 CEILING

▪ Material	: Wet-Process Mineral Fibre Ceiling
▪ Surface Finish	: Ethene Coating (2 Coats) / White Colour
▪ Panel Size	: 600mm x 600mm x 15mm
▪ Surface Burning Characteristic	: Class 1 BS476: Part 6 and Part 7 : Class A ASTM E-84
▪ Noise Reduction Coefficients	: NRC 0.55
▪ Relative Humidity / Temperature Resistance	: RH95 / 40°C
▪ Light Reflectance	: RL-0.836
▪ Thermal Resistance R Value	: 0.31 (m ² .k/w)
▪ Bending Strength	: 194N
▪ Formaldehyde FREE	: PASS
▪ Asbestos Contains	: NONE
▪ Low Emission (VOC Class)	: LOW

B.8 PLUMBING

All sanitary wares shall be "ARMITAGE SHANKS/ TOTO/AMERICAN STANDARD/COTTO" and faucets shall be "ARMITAGE SHANKS/BRICON/TOTO or other approved equivalent. Cold and drinking water pipes – Stainless steel B.S 4127 and shall be concealed/ lay in concrete. Hot water pipes – Copper tube B.S 2871 and shall be concealed/ lay in concrete. All water supply, waste and soil pipe connected to the nearest existing / manhole.

B.9 FLUSH DOOR

All flush door faced both sides with Laminated Formica shall be finishing smooth with semi-gloss spray varnish. All door frames to be used shall be selected hardwood and treated.

B.10 WATERPROOFING

Application of waterproofing shall be done by Specialist Contractor with a written guarantee period not less than 5 years. The Contractor shall mentioned or filled of the proposed material to be used stipulated in the bill of quantities and submit brochure for approval of the S.O

B.11 FLOOR TILES

WALL FLOOR TILES

The tile to be polished homogeneous finishes, fixed with straight joint as ordered, bedded in cement mortar (1:2) and jointed in white or coloured cement.

Wall to be tiled are to be rendered with cement mortar consisting of 1 part Portland cement to 3 pat sand, the surface of the rendering to be left slightly rough. Just before the rendering is applied the wall is to be well soaked with clean water and the rendering is to be similarly treated just before the tile are fixed.

FLOOR TILE

The tile to be non-slip homogeneous finishes, fixed with straight joint as ordered, bedded in cement mortar (1:2) and jointed in white or coloured cement.

Wall to be tiled are to be rendered with cement mortar consisting of 1 part Portland cement to 3 pat sand, the surface of the rendering to be left slightly rough. Just before the rendering is applied the wall is to be well soaked with clean water and the rendering is to be similarly treated just before the tile are fixed.

B.12 ELECTRICAL WORK

The works shall comprise the supply of all materials, installation and commissioning testing, the works shall comply with the latest version of the IEE wiring regulations and to the satisfaction of the Director of Electrical Services, Brunei Darussalam. Materials to supply shall comply with the relevant British Standard and /or approved by PUB Singapore or SISIR.

B.13 ALUMINUM FRAME

All windows shall be 3" thick aluminium powder coated of heavy-duty frames and accessories and shall be of quality manufacture. It shall be of the type fabricated in the best workman like manner, free from any defects what so ever and shall be able to withstand the normal tropical atmospheric condition. Contractor shall submit a sample section to be used for approval of the S.O.

B.14 SPECIFICATION AND CONDITION OF CONTRACT / ENGAGEMENT OF SPECIALIST

All tenderer's are required to comply / submit:

- Safety, Health and Welfare of Workforce
- Program Chart
- Detail Working Drawing (As-Built Drawing)
- To engage an independent specialist in testing, approval certification and warranty of buildings and M & E materials, equipment, facilities due to relocation, supply, fix, lay and reinstall.

PT 1

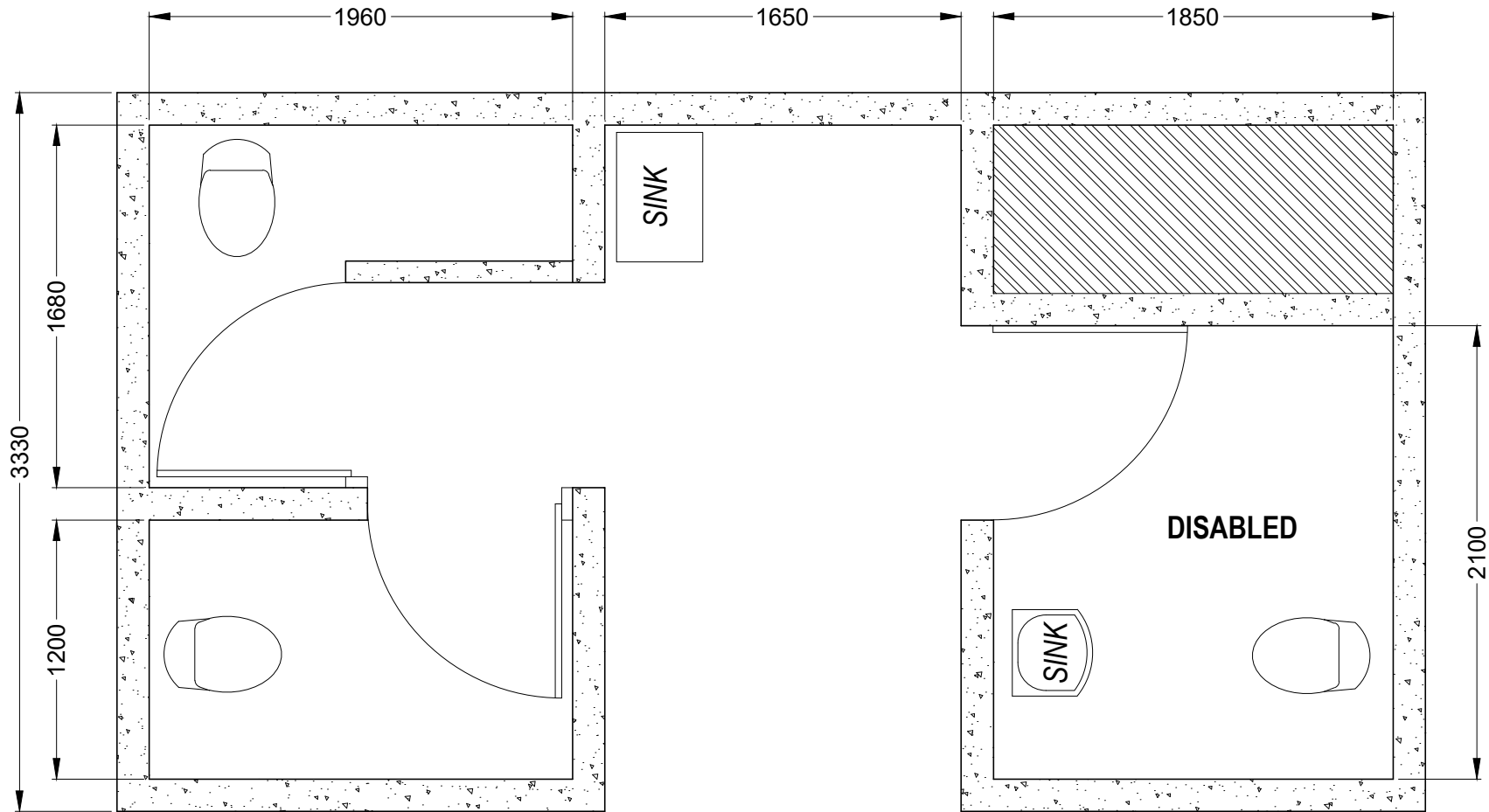

NOTES :

HEIGHT: 2540MM



**PROJECT DEVELOPMENT
ESTATE MANAGEMENT
MINISTRY OF HEALTH**

PROJECT TITLE :

UPGRADING WORKS FOR
PUBLIC TOILET AT GROUND FLOOR,
SURI SERI BEGAWAN HOSPITAL,
KUALA BELAIT,
MINISTRY OF HEALTH

DRAWING TITLE :

**FLOOR PLAN
PT 1**

DRAWN BY :	AZRIANA H.A.HALIM
CHECKED BY :	
DATE :	07.01.2026
SCALE :	
DRWNG. NO :	D1

PT 2

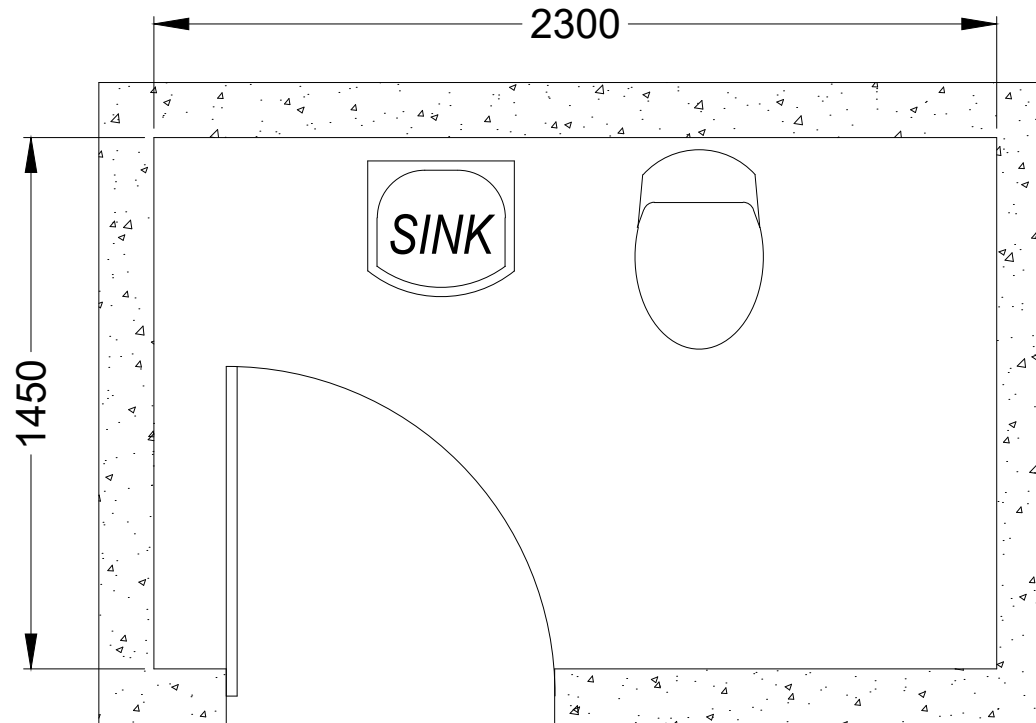

NOTES :

HEIGHT: 2540MM



PROJECT DEVELOPMENT
ESTATE MANAGEMENT
MINISTRY OF HEALTH

PROJECT TITLE :

UPGRADING WORKS FOR
PUBLIC TOILET AT GROUND FLOOR,
SURI SERI BEGAWAN HOSPITAL,
KUALA BELAIT,
MINISTRY OF HEALTH

DRAWING TITLE :

FLOOR PLAN
PT 2

DRAWN BY : AZRIANA H.A.HALIM

CHECKED BY :

DATE : 07.01.2026

SCALE :

DRWNG. NO : D2

PT 3

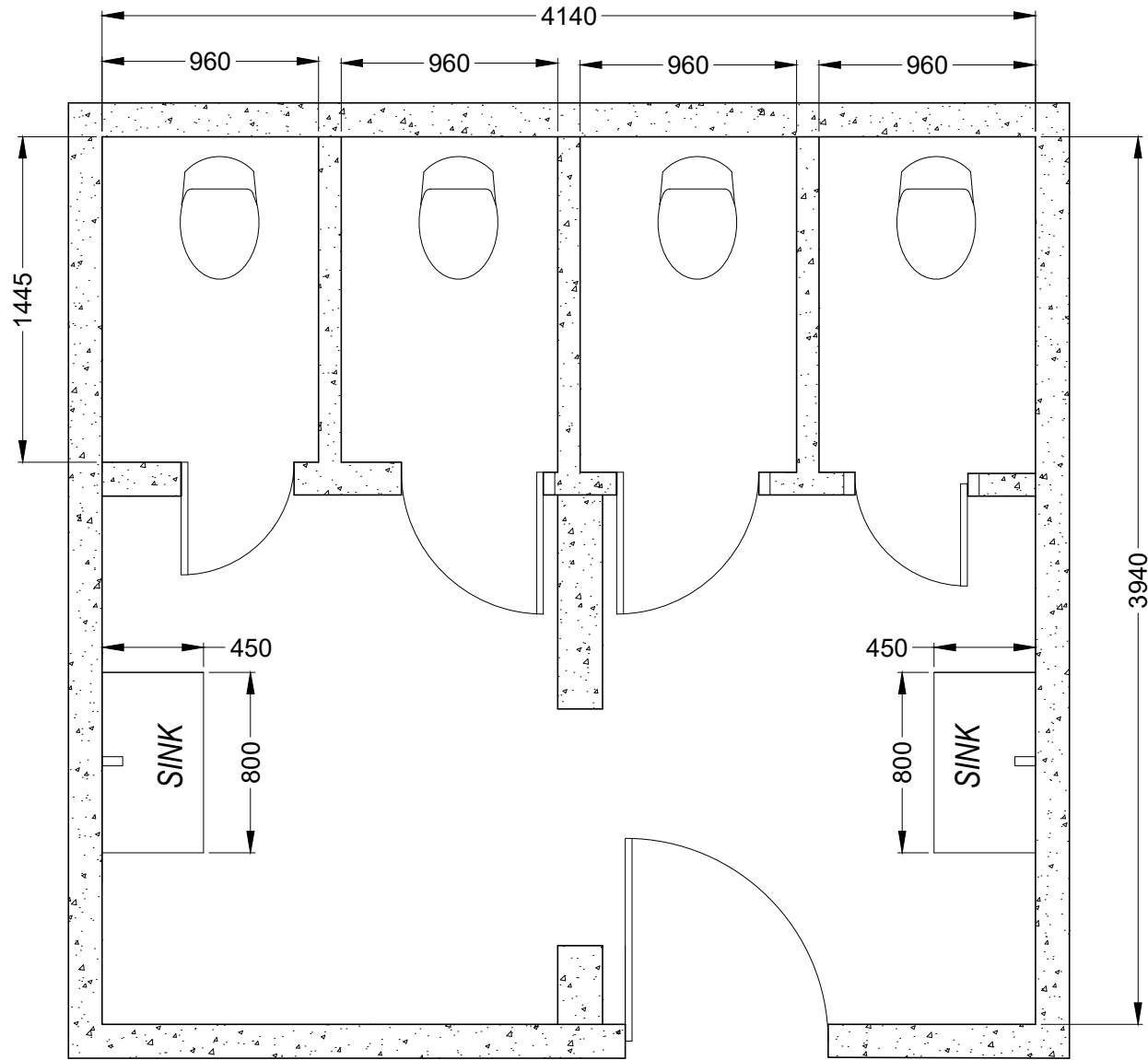

NOTES :

HEIGHT: 2730MM



PROJECT DEVELOPMENT
ESTATE MANAGEMENT
MINISTRY OF HEALTH

PROJECT TITLE :

UPGRADING WORKS FOR
PUBLIC TOILET AT GROUND FLOOR,
SURI SERI BEGAWAN HOSPITAL,
KUALA BELAIT,
MINISTRY OF HEALTH

DRAWING TITLE :

FLOOR PLAN
PT3

DRAWN BY : AZRIANA H.A.HALIM

CHECKED BY :

DATE : 07.01.2026

SCALE :

DRWNG. NO : D3

PT 4

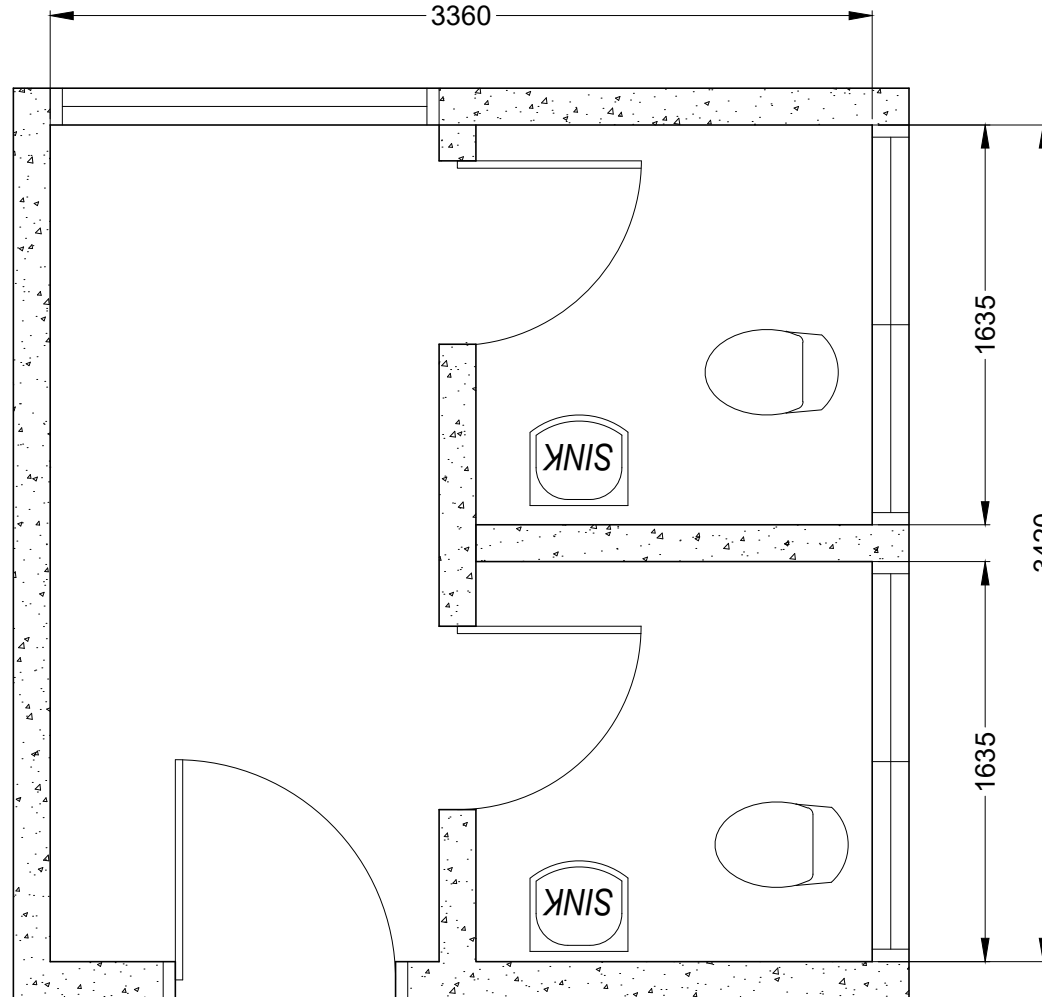

NOTES :

HEIGHT: 2540MM



PROJECT DEVELOPMENT
ESTATE MANAGEMENT
MINISTRY OF HEALTH

PROJECT TITLE :

UPGRADING WORKS FOR
PUBLIC TOILET AT GROUND FLOOR,
SURI SERI BEGAWAN HOSPITAL,
KUALA BELAIT,
MINISTRY OF HEALTH

DRAWING TITLE :

FLOOR PLAN
PT4

DRAWN BY : AZRIANA H.A.HALIM

CHECKED BY :

DATE : 07.01.2026

SCALE :

DRWNG. NO : D4

PT 5

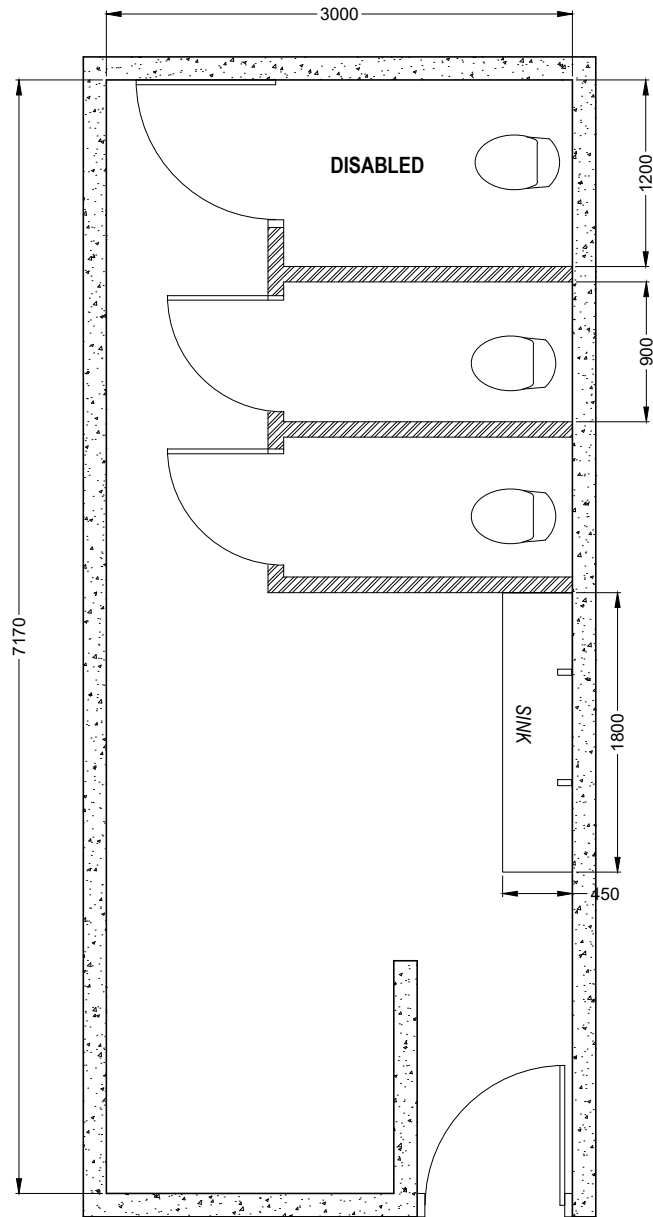

PT 6

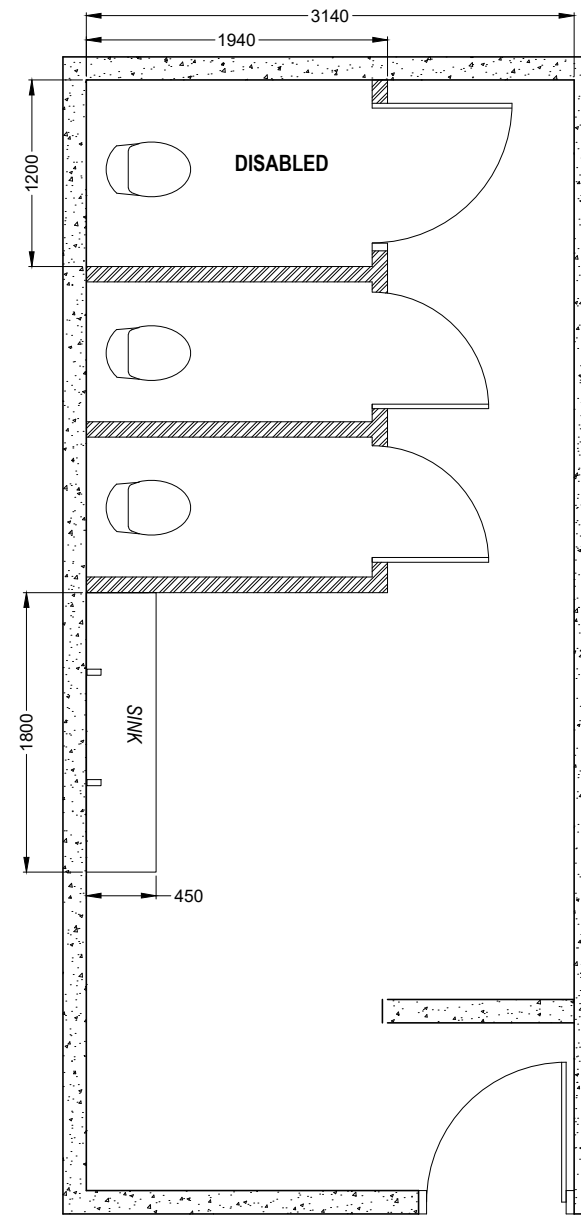

NOTES :

HEIGHT: 2730MM



**PROJECT DEVELOPMENT
ESTATE MANAGEMENT
MINISTRY OF HEALTH**

PROJECT TITLE :

UPGRADING WORKS FOR
PUBLIC TOILET AT GROUND FLOOR,
SURI SERI BEGAWAN HOSPITAL,
KUALA BELAIT,
MINISTRY OF HEALTH

DRAWING TITLE :

**FLOOR PLAN
PT 5 AND PT 6**

DRAWN BY :	AZRIANA H.A.HALIM
CHECKED BY :	
DATE :	07.01.2026
SCALE :	
DRWNG. NO :	D5

SECTION 3

CONTENTS

		PAGES
SCHEDULE A	SUMMARY OF TENDER	1 - 10
SCHEDULE B	TENDER FORM	11 – 12
SCHEDULE C	INFORMATION SUMMARY	13
SCHEDULE D	SUB-CONTRACTS	14
SCHEDULE E	COMPANY'S BACKGROUND	15
SCHEDULE F	REFERENCES	16
SCHEDULE G	LETTER OF DECLARATION	17
SCHEDULE H	STATEMENT OF COMPLIANCE	18

**UPGRADING WORKS FOR PUBLIC TOILET AT GROUND FLOOR, SURI SERI BEGAWAN
HOSPITAL KUALA BELAIT, KEMENTERIAN KESIHATAN**

SUMMARY OF PRICES

ITEM	DESCRIPTION	PRICE (B\$)
A	PAGE 1	\$
B	PAGE 2	\$
C	PAGE 3	\$
D	PAGE 4	\$
E	PAGE 5	\$
F	PAGE 6	\$
TOTAL AMOUNT TO BE CARRIED FORWARD TO FINAL SUMMARY		\$

The electrical sub-contractor shall be registered with the Ministry of Development under category E01 with valid workers registration pass from Department of Electrical Services.

The total tender price for the Electrical Installation as described or referred to the attached drawings, specifications in accordance with general conditions and preliminaries is made up of the complete supply, installation, testing and putting into commission, handing over in approved working order and maintenance thereafter for period of nine (9) months.

Tenderers are advised to read the specification and drawing in detail before submitting their prices and shall include all incidental work pertaining thereto even though not specifically mentioned herein or shown on the drawings and which deem necessary for the specification of systems operation and performance.

The tender price shall include all custom duties, air-freight charges, sale tax and other taxes, insurance, transportation and hoisting of equipment for all the materials as required to meet the completion period as specified.

Official Stamp of Tenderer

Signature of Tenderer

Date: _____

ITEM NO.	DESCRIPTION	QTY	UNIT	AMOUNT		
				RATE	\$	c
	<p>Note: The contractor shall carry out 'site visit' inspection and take into account all aspects and conditions of site before submitting his quotation. The contractor must fill this schedule at the time of tendering. Supply all materials, labour, tools and everything else deemed necessary to carry out work as specified. Contractor having submitted their prices are considered as having visited the site. No claims for additional payment will be entertained on the ground of misunderstanding or misinterpretation of the conditions, measurement etc. All measurements stated herein or in the drawing are meant to be rough guidance only and subject to re-measurement on site. Contractor to ensure the safety, health and welfare of workforce that includes the provision of PPE for all personnel who involved in the site activities. Contractor are to clean up and remove all debris offsite at their own expenses. Contractor is to protect the occupant's properties. All contractor required to comply with the Specification and Conditions of Contract (Scope of Work and Material Specification) Contractor to comply with all the requirements as specified in the Infection Control Risk Assessment (ICRA) guidelines as attached.</p>					
1.0	<u>DEMOLISHING / REMOVING / DISMANTLING</u>					
1.1	Demolishing, hacking, screeding and removing all the existing toilet bowls, wall and floor tiles, sink water tap, flexible hoses, existing doors or any objects, materials, devices of area and dispose of site to the contractor's own site as to replace with new material as per instructed by the S.O in charge for the following toilet:					
	a) PT1	1	Lot			
	b) PT2	1	Lot			
	c) PT3	1	Lot			
	d) PT4	1	Lot			
	e) PT5	1	Lot			
	f) PT6	1	Lot			
2.0	<u>BUILDING WORKS</u>					
2.1	Supply material and tools to construct new screed layer with waterproofing additives, inclusive necessary levelling; 50mm thick for the following floor area:					
	a) PT1	18	m ₂			

ITEM NO.	DESCRIPTION	QTY	UNIT	AMOUNT		
				RATE	\$	c
	b) PT2	3.4	m ₂			
	c) PT3	16	m ₂			
	d) PT4	10.3	m ₂			
	e) PT5	22	m ₂			
	f) PT6	23	m ₂			
2.2	Apply monolithic brush on type water proofing inclusive 1800mm high surrounding wall to all the following area: Contractor to submit catalogue					
	a) PT1	58	m ₂			
	b) PT2	14	m ₂			
	c) PT3	45	m ₂			
	d) PT4	25	m ₂			
	e) PT5	58	m ₂			
	f) PT6	60	m ₂			
2.3	Supply and laid new 600mm x 600mm non-slip homogeneous floor tile and all other accessories required for the following floor area. Contractor to submit catalogue.					
	a) PT1	18	m ₂			
	b) PT2	3.4	m ₂			
	c) PT3	16	m ₂			
	d) PT4	10.3	m ₂			
	e) PT5	22	m ₂			
	f) PT6	23	m ₂			
2.4	Supply and fix new 300mm x 600mm by using polished homogeneous wall tile or other approved equivalent from floor to ceiling inclusive trimming with pattern and all others accessories required for the following area: Contractor to submit catalogue.					
	a) PT1	58	m ₂			
	b) PT2	29	m ₂			
	c) PT3	45	m ₂			
	d) PT4	57	m ₂			

ITEM NO.	DESCRIPTION	QTY	UNIT	AMOUNT		
				RATE	\$	c
	e) PT5	85	m ₂			
	f) PT6	85	m ₂			
2.5	Supply and install fixed/concealed ceiling & steel frame by using 12mm thick moisture resistant gypsum board, seamless joint finishing c/w framework T-bar aluminium module suspension system, hanger support, to make opening for M&E services points and apply 2 coats of finishing paint as per instructed by the S.O. for the following area:					
	a) PT1	18	m ₂			
	b) PT2	3.4	m ₂			
	c) PT3	16	m ₂			
	d) PT4	10.3	m ₂			
2.6	To replace and install new suspended ceiling complete with tee, wall angle and necessary accessories. To follow existing size					
	a) PT5	22	m ₂			
	b) PT6	23	m ₂			
2.7	To Supply and construct a solid surface integrated trough sink, concrete finish with smooth seamless surface and adequate fall to waste, complete with concealed base supports, 1 tap hole for wall-mounted sensor tap, PVC bottle trap, waste plug and chain, cold water piping, connectors and all necessary plumbing fittings. Measurement to verify on site. Refer to sample photo attached.					
	a) PT1	1	Lot			
	b) PT2	1	Lot			
	c) PT3	2	Lot			
	d) PT4	2	Lot			
2.8	To Supply and construct a solid surface integrated trough sink, concrete finish with smooth seamless surface and adequate fall to waste, complete with concealed base supports, 2 taps hole for wall-mounted sensor tap, PVC bottle trap, waste plug and chain, cold water piping, connectors and all necessary plumbing fittings. Measurement to verify on site.					
	e) PT5	1	Lot			
	f) PT6	1	Lot			
2.9	Supply and install P-trap exposed type toilet bowl with toilet waste pipe 100mm in diameter, approved					

ITEM NO.	DESCRIPTION	QTY	UNIT	AMOUNT		
				RATE	\$	c
	Dual flush closed coupled toilet c/w seat cover, proper connector, cold water supply pipe and all other plumbing works required to suit the new layout. Price shall include any modification to waste & soil pipe inclusive fittings. Contractor to submit catalogue.					
	a) PT1	2	Nos			
	b) PT2	1	No			
	c) PT3	4	Nos			
	d) PT4	2	Nos			
	e) PT5	2	Nos			
	f) PT6	2	Nos			
2.10	Supply and install stainless steel nozzle type flexible hose spray 1.5m long c/w stop angle cock and all other plumbing works required. Contractor to submit catalogue.					
	a) PT1	3	Set			
	b) PT2	1	Set			
	c) PT3	4	Set			
	d) PT4	2	Set			
	e) PT5	3	Set			
	f) PT6	3	Set			
2.11	To supply and install Wall-mounted Single sheet toilet tissue dispenser made of high-gloss ABS plastic or equivalent c/w all necessary fixing accessories. Contractor to submit catalogue.					
	a) PT1	2	No			
	b) PT2	1	No			
	c) PT3	2	No			
	d) PT4	2	No			
	e) PT5	1	No			
	f) PT6	1	No			
2.12	Supply and install stainless steel wall-mounted toilet roll holder for the following toilets. Contractor to submit catalogue.					
	a) PT1	3	No			

ITEM NO.	DESCRIPTION	QTY	UNIT	AMOUNT		
				RATE	\$	c
	b) PT2	1	No			
	c) PT3	4	No			
	d) PT4	2	No			
	e) PT5	3	No			
	f) PT6	3	No			
2.13	Supply and install nylon single robe hook for the following toilets. Contractors to submit catalogue/sample.					
	a) PT1	3	No			
	b) PT2	1	No			
	c) PT3	4	No			
	d) PT4	2	No			
	e) PT5	3	No			
	f) PT6	3	No			
2.14	Replace window gaskets, hinges c/w lockset and all necessary works to existing windows for the following toilets.					
	a) PT4	4	No			
2.15	Supply and install new toilet cubicle door using HPL or equivalent c/w stainless steel hinges, latches, locks, door knob and U-channel framing. Contractors to submit catalogue/sample and size to measure and verify on site.					
	a) PT3	4	Set			
	b) PT5	3	Set			
	c) PT6	3	Set			
2.16	Supply and install new toilet door using HPL or equivalent c/w stainless steel hinges, latches, locks, door knob and U- channel framing. Contractors to submit catalogue/sample and size to measure and verify on site.					
	a) PT1	2	Set			
	b) PT4	2	Set			
2.17	Supply and install new Aluminium swing door half-fluted glass panel and lower aluminium louver panel including aluminium frame, lever handle with mortise lock, hinges, glazing, c/w related accessories and all necessary ironmongery for the following toilets entrance. Size to follow existing					

ITEM NO.	DESCRIPTION	QTY	UNIT	AMOUNT		
				RATE	\$	c
	door size. Contractors to submit catalogue/sample.					
	a) PT1	1	Set			
2.18	Supply and install new Aluminium swing door half-fluted clear glass panel top including aluminium frame, lever handle with mortise lock, hinges, glazing, c/w related accessories and all necessary ironmongery for the following toilets entrance. Size to follow existing door size. Contractors to submit catalogue/sample.					
	a) PT4	1	Set			
2.19	Supply and install new single leaf anti bacteria HPL flush door with laminated finish, door frame, door lintels, door closer, single-sided stainless steel door handle and all other ironmongeries required. Size to follow existing door size. Contractors to submit catalogue/sample.					
	a) PT1	2	Set			
	b) PT2	1	Set			
	c) PT3	1	Set			
	d) PT5	1	Set			
	e) PT6	1	Set			
2.20	To replace existing floor traps with new floor traps and other related works for the following toilets: Contractor to submit catalogues					
	a) PT1	4	Nos			
	b) PT2	1	No			
	c) PT3	6	Nos			
	d) PT4	2	Nos			
	e) PT5	4	Nos			
	f) PT6	4	Nos			
2.21	Supply and install standard disabled toilet bowl and fittings c/w all fixing accessories / fittings required; wash hand basin hanged to wall, swing up grab bar and L-shape grab bar for all disabled toilet; to follow existing.					
	a) PT1	2	Nos			
	b) PT2	1	No			
	c) PT3	2	Nos			

ITEM NO.	DESCRIPTION	QTY	UNIT	AMOUNT		
				RATE	\$	c
	d) PT4	2	Nos			
	e) PT5	1	No			
	f) PT6	1	No			
2.22	Supply and install wall mirror and other related accessories for the following toilets.Measurement to verify on site. Contractor to submit catalogues					
	a) PT1	8	Nos			
	b) PT3	2	Nos			
3.0	<u>PAINTING WORKS</u>					
3.1	To repaint all interior wall, including surface preparation, patching, priming and finishing with 2 coats of approved anti-mould emulsion paint and finish.					
	a) PT1 Entrance Area 5.5m2	1	Lot			
4.0	<u>ELECTRICAL WORKS</u>					
4.1	Supply and install new recessed, round type 12W LED downlight in daylight and including all other associated works required (including cabling and wiring works) for the					
	a) PT1	8	Nos			
	b) PT2	2	Nos			
	c) PT3	8	Nos			
	d) PT4	4	Nos			
	e) PT5	8	Nos			
	f) PT6	8	Nos			
4.2	Supply and install new 8-inch wall mounted exhaust fan type c/w accessories, cabling and termination for electrical wiring for the following toilets:					
	a) PT4	3	Nos			
4.3	Supply, install and replace new 8-inch ceiling mounted or equivalent exhaust fan type c/w accessories, cabling and termination for electrical wiring for the following toilets:					
	a) PT1	3	Nos			
	b) PT2	1	No			
	c) PT3	4	Nos			

ITEM NO.	DESCRIPTION	QTY	UNIT	AMOUNT		
				RATE	\$	c
	d) PT4	4	Nos			
	e) PT5	4	Nos			
	f) PT6					
4.4	Supply and install new gang lighting switch c/w necessary accessories needed as per instructed by the S.O for the following location:					
	a) PT1	1	Lot			
	b) PT2	1	Lot			
	c) PT3	1	Lot			
	d) PT4	1	Lot			
	e) PT5	1	Lot			
	f) PT6	1	Lot			
5.0	<u>EMERGENCY ALERT SYSTEM</u>					
	Supply and install the following including all necessary termination, accessories fitting, tagging label, programming, testing and commissioning and not limited to as specified but to good working condition. All fittings and device offered must be DES /MOD approved vendor list or MOH standard.					
5.1	Supply and install 8 zone control panel (expandable to 32 zones) c/w transformer, built in charger, 7.2Ah backup, auto dialer and termination at registration counter.	1	No			
5.2	Supply and install LCD +32 zone LCD keypad. Location to be determined at site.	1	No			
5.3	8 zone expanders	2	Nos			
5.4	12V DC Alarm strobe light	1	No			
5.5	Programming, testing and commissioning	1	No			
5.6	Wiring of Emergency Alert call Buttons c/w cover casing, attach on the walls, at all toilet Ground Floor using CAT6 cable to a new system panel at the assigned location station c/w other necessary accessories deemed required for the proper function of the system	16	Nos			
5.7	Bilders work including cutting of ceiling, re-installing works including repainting, making good of any ceiling/wall etc affected by installation works, to its original state.	1	Lot			
5.8	Emergency call alert button/pullcord suitable for toilet c/w indicator lights, conduiting/wiring/cablings and other necessary accessories.					
	a) Emergency call alert button/pullcord only	16	Nos			

ITEM NO.	DESCRIPTION	QTY	UNIT	AMOUNT		
				RATE	\$	c
	b) Conduiting & cabling works only	16	Nos			
	Brand:					
	Warranty:					
6.0	Signages					
6.1	To fabricate, supply and install new acrylic signage as per client's requirements and S.O instructions:					
	a) PT1	1	No			
	b) PT2	1	No			
	c) PT3	1	No			
	d) PT4	1	No			
	e) PT5	1	No			
	f) PT6	1	No			
TOTAL AMOUNT FOR THE SUMMARY OF TENDER						